



Surge protection for CCTV systems

White Paper



Contents

Camera connected to a building with external lightning protection system and lightning current carrying surge protective devices on both ends

Camera connected to a building without external lightning protection system with surge protective devices on both ends

IP camera with surge protective devices on both ends

Surge protection for CCTV systems

White Paper



CCTV systems are used in all sectors for access control and facility supervision. In the following, surge protection measures will be described which meet the high availability requirements of CCTV systems.

A CCTV system consists of at least one camera, one monitor and one suitable video transmission path. Remotely controlled camera stations are typically equipped with a pan/tilt head which allows the operator to individually adjust the position and the perspective of the station.

In the simplest case, the transmission line between the junction box and the monitor is a coaxial or a balanced two-wire

cable. Coaxial cables are used for unbalanced transmission, in other words the video signal is transmitted through the core of the coaxial cable (inner conductor). The shield (earth) is the reference point for signal transmission. Balanced transmission (baluns) where the coaxial signal is converted to a two-wire signal is used for two-wire cables.

The voltage supply cable is often routed separately. In case of IP cameras, however, a single cable is used for the transmission of the video signal and for voltage supply. An RS 485 bus controls the panning and tilting of the camera.

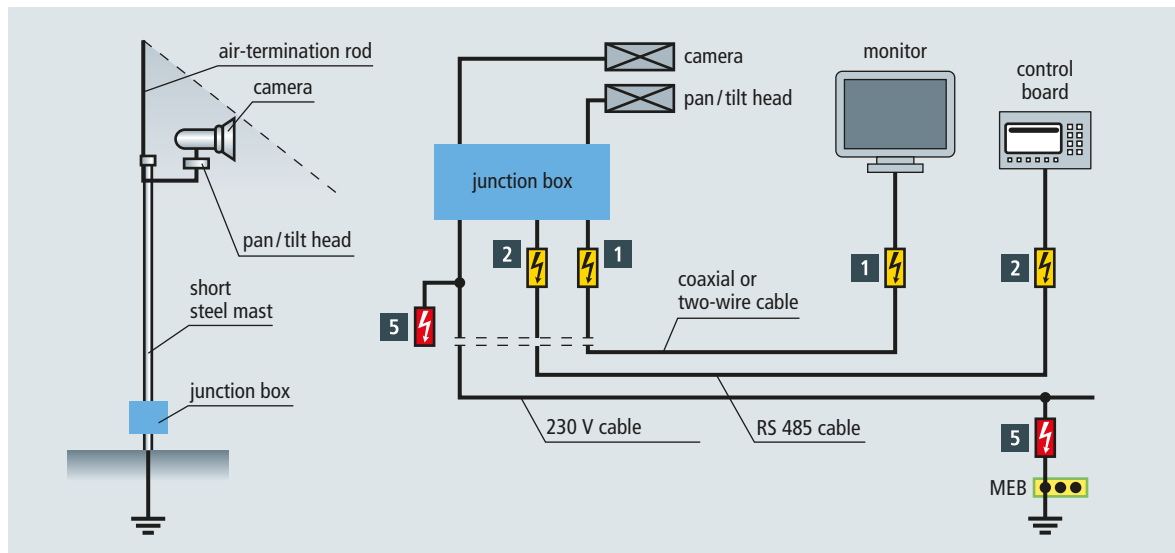

Figure 1 Camera connected to a building with external lightning protection system and lightning current carrying surge protective devices on both ends

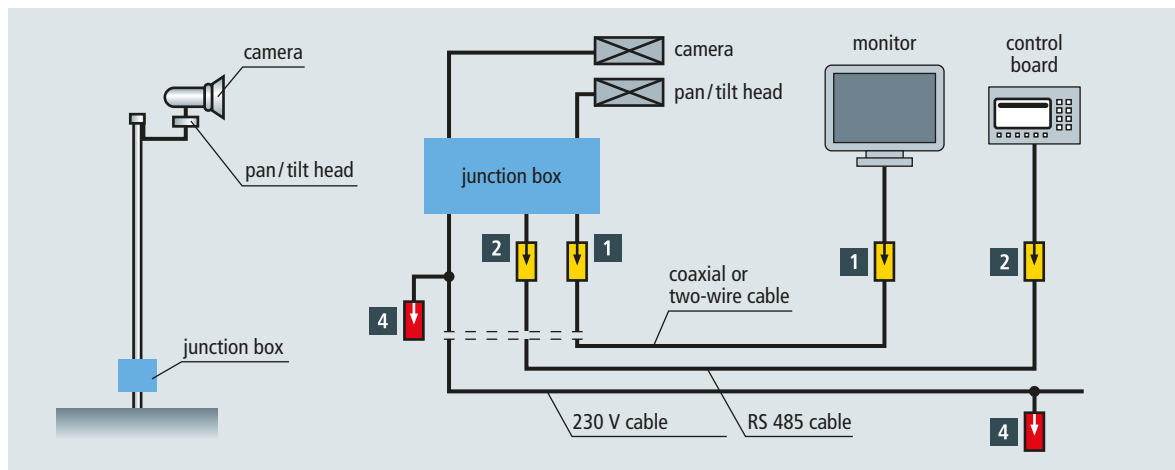

Figure 2 Camera connected to a building without external lightning protection system with surge protective devices on both ends

Surge protection for CCTV systems

White Paper

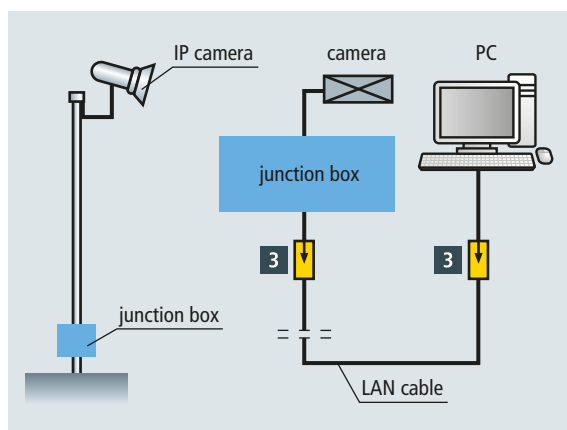

Figure 3 IP camera with surge protective devices on both ends

Building with external lightning protection system

Figure 1 shows a CCTV camera installed at a mast. A direct lightning strike to the camera can be prevented if an air-termination rod is installed at the mast. The connecting cable between the junction box and the camera is typically installed in

the metal mast. If this is not possible, the camera cable must be routed in a metal tube and conductively connected to the mast. In this case, surge protective devices do not have to be installed in the junction box if the cable length does not exceed some metres.

Lightning equipotential bonding must be established at the entrance point into the building for all cables mentioned above which are routed from the junction box at the mast to a building with external lightning protection system (**Table 1**).

If cameras are mounted on the outer façade of a building, it should be ensured that the camera is located in the protected volume or is protected from direct lightning strikes by an air-termination system.

Building without external lightning protection system

If buildings are not equipped with an external lightning protection system, the risk resulting from a direct or nearby lightning strike to the building is assumed to be low and is thus acceptable. In this case, the installation of surge arresters provides sufficient protection (**Table 1**).

Figure 2 shows a multi-line CCTV system and **Figure 3** a digital IC camera system.

No.	Protection for...	Surge protective device	Part No.
Surge protective devices for information technology systems			
1	Two-wire cable (video transmission)	BLITZDUCTOR XT / BLITZDUCTOR SP + BXT BAS	920 271 / 926 271 920 300
	Coaxial cable (video transmission system)	UGKF BNC or DGA BNC VCID	929 010 909 711
2	RS 485 cable (camera controller)	BLITZDUCTOR XT / BLITZDUCTOR SP + BXT BAS	920 271 / 926 271 920 300
3	LAN cable (IP camera)	DEHNpatch DPA M CAT6 RJ45S 48	929 100
		DEHNpatch DPA M CLE RJ45B 48	929 121
Surge protective devices for power supply systems – Surge arresters			
4	a.c. TN system	DEHNguard DG M TN 275	952 200
	a.c. TT system	DEHNguard DG M TT 2P 275	952 110
Surge protective devices for power supply systems – Combined arresters			
5	a.c. TN system	DEHNshield DSH TN 255	941 200
	a.c. TT system	DEHNshield DSH TT 255	941 110

Table 1 Surge protective devices shown in Figures 1–3

DEHNshield

DSH TT 2P 255 (941 110)

- Application-optimised and prewired spark-gap-based type 1 and type 2 combined lightning current and surge arrester
- Space-saving arrester for compact and simply equipped electrical installations with reduced technical requirements
- Capable of protecting terminal equipment



Figure without obligation

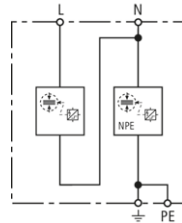

Basic circuit diagram DSH TT 2P 255

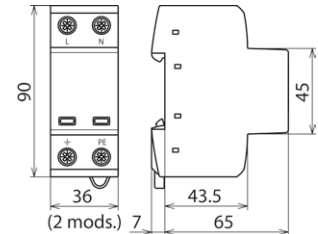

Dimension drawing DSH TT 2P 255

Application-optimised and prewired combined lightning current and surge arrester for single-phase TT and TN-S systems ("1+1" circuit).

Type	DSH TT 2P 255
Part No.	941 110
SPD according to EN 61643-11 / IEC 61643-11	type 1 + type 2 / class I + class II
Energy coordination with terminal equipment (≤ 5 m)	type 1 + type 2 + type 3
Nominal a.c. voltage (U_N)	230 V (50 / 60 Hz)
Max. continuous operating a.c. voltage (U_C)	255 V (50 / 60 Hz)
Lightning impulse current (10/350 μ s) [L+N-PE] (I_{total})	25 kA
Specific energy [L+N-PE] (W/R)	156.25 kJ/ohms
Lightning impulse current (10/350 μ s) [L-N]/[N-PE] (I_{imp})	12.5 / 25 kA
Specific energy [L-N]/[N-PE] (W/R)	39.06 / 156.25 kJ/ohms
Nominal discharge current (8/20 μ s) [L-N]/[N-PE] (I_n)	12.5 / 25 kA
Voltage protection level [L-N]/[N-PE] (U_p)	≤ 1.5 / ≤ 1.5 kV
Follow current extinguishing capability [L-N]/[N-PE] (I_{fl})	25 kA _{rms} / 100 A _{rms}
Follow current limitation / Selectivity	no tripping of a 32 A gL/gG fuse up to 25 kA _{rms} (prosp.)
Response time (t_A)	≤ 100 ns
Max. mains-side overcurrent protection	160 A gL/gG
Temporary overvoltage (TOV) [L-N] (U_T) – Characteristic	440 V / 120 min. – withstand
Temporary overvoltage (TOV) [N-PE] (U_T) – Characteristic	1200 V / 200 ms – withstand
Operating temperature range (T_U)	-40 °C ... +80 °C
Operating state / fault indication	green / red
Number of ports	1
Cross-sectional area (L, N, PE, \pm) (min.)	1.5 mm ² solid / flexible
Cross-sectional area (L, N, PE, \pm) (max.)	35 mm ² stranded / 25 mm ² flexible
For mounting on	35 mm DIN rails acc. to EN 60715
Enclosure material	thermoplastic, red, UL 94 V-0
Place of installation	indoor installation
Degree of protection	IP 20
Capacity	2 module(s), DIN 43880
Approvals	KEMA, VDE, UL
Weight	275 g
Customs tariff number	85363030
GTIN	4013364137899
PU	1 pc(s)

DEHNshield

DSH TN 255 (941 200)

- Application-optimised and prewired spark-gap-based type 1 and type 2 combined lightning current and surge arrester
- Space-saving arrester for compact and simply equipped electrical installations with reduced technical requirements
- Capable of protecting terminal equipment



Figure without obligation

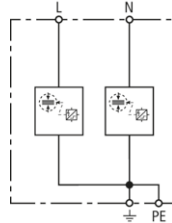

Basic circuit diagram DSH TN 255

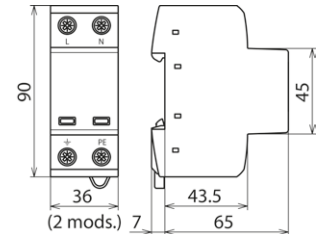

Dimension drawing DSH TN 255

Application-optimised and prewired combined lightning current and surge arrester for single-phase TN systems.

Type	DSH TN 255
Part No.	941 200
SPD according to EN 61643-11 / IEC 61643-11	type 1 + type 2 / class I + class II
Energy coordination with terminal equipment (≤ 5 m)	type 1 + type 2 + type 3
Nominal a.c. voltage (U_N)	230 V (50 / 60 Hz)
Max. continuous operating a.c. voltage (U_C)	255 V (50 / 60 Hz)
Lightning impulse current (10/350 μ s) [L+N-PE] (I_{total})	25 kA
Specific energy [L+N-PE] (W/R)	156.25 kJ/ohms
Lightning impulse current (10/350 μ s) [L, N-PE] (I_{imp})	12.5 kA
Specific energy [L,N-PE] (W/R)	39.06 kJ/ohms
Nominal discharge current (8/20 μ s) [L/N-PE]/[L+N-PE] (I_n)	12.5 / 25 kA
Voltage protection level [L-PE]/[N-PE] (U_P)	≤ 1.5 / ≤ 1.5 kV
Follow current extinguishing capability a.c. (I_{fi})	25 kA _{rms}
Follow current limitation / Selectivity	no tripping of a 32 A gL/gG fuse up to 25 kA _{rms} (prosp.)
Response time (t_A)	≤ 100 ns
Max. mains-side overcurrent protection	160 A gL/gG
Temporary overvoltage (TOV) [L-N] (U_T) – Characteristic	440 V / 120 min. – withstand
Operating temperature range (T_U)	-40 °C ... +80 °C
Operating state / fault indication	green / red
Number of ports	1
Cross-sectional area (L, N, PE, \pm) (min.)	1.5 mm ² solid / flexible
Cross-sectional area (L, N, PE, \pm) (max.)	35 mm ² stranded / 25 mm ² flexible
For mounting on	35 mm DIN rails acc. to EN 60715
Enclosure material	thermoplastic, red, UL 94 V-0
Place of installation	indoor installation
Degree of protection	IP 20
Capacity	2 module(s), DIN 43880
Approvals	KEMA, VDE, UL
Weight	250 g
Customs tariff number	85363030
GTIN	4013364138209
PU	1 pc(s)

DEHNguard

DG M TT 2P 275 (952 110)

- Prewired complete unit consisting of a base part and plug-in protection modules
- High discharge capacity due to heavy-duty zinc oxide varistors / spark gaps
- High reliability due to "Thermo Dynamic Control" SPD monitoring device



Figure without obligation

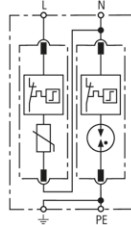

Basic circuit diagram DG M TT 2P 275

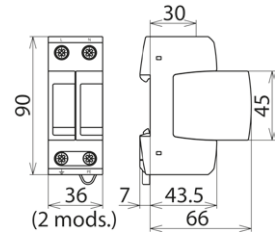

Dimension drawing DG M TT 2P 275

Modular surge arrester for use in single-phase TT and TN systems ("1+1" circuit).

Type	DG M TT 2P 275
Part No.	952 110
SPD according to EN 61643-11 / IEC 61643-11	type 2 / class II
Nominal a.c. voltage (U_N)	230 V (50 / 60 Hz)
Max. continuous operating a.c. voltage [L-N] (U_C)	275 V (50 / 60 Hz)
Max. continuous operating a.c. voltage [N-PE] (U_C)	255 V (50 / 60 Hz)
Nominal discharge current (8/20 μ s) (I_n)	20 kA
Max. discharge current (8/20 μ s) (I_{max})	40 kA
Lightning impulse current (10/350 μ s) [N-PE] (I_{imp})	12 kA
Voltage protection level [L-N] (U_P)	≤ 1.5 kV
Voltage protection level [L-N] at 5 kA (U_P)	≤ 1 kV
Voltage protection level [N-PE] (U_P)	≤ 1.5 kV
Follow current extinguishing capability [N-PE] (I_n)	100 A _{rms}
Response time [L-N] (t_A)	≤ 25 ns
Response time [N-PE] (t_A)	≤ 100 ns
Max. mains-side overcurrent protection	125 A gG
Short-circuit withstand capability for max. mains-side overcurrent protection (I_{SCCR})	50 kA _{rms}
Temporary overvoltage (TOV) [L-N] (U_T) – Characteristic	335 V / 5 sec. – withstand
Temporary overvoltage (TOV) [L-N] (U_T) – Characteristic	440 V / 120 min. – safe failure
Temporary overvoltage (TOV) [N-PE] (U_T) – Characteristic	1200 V / 200 ms – withstand
Operating temperature range (T_U)	-40 °C ... +80 °C
Operating state / fault indication	green / red
Number of ports	1
Cross-sectional area (min.)	1.5 mm ² solid / flexible
Cross-sectional area (max.)	35 mm ² stranded / 25 mm ² flexible
For mounting on	35 mm DIN rails acc. to EN 60715
Enclosure material	thermoplastic, red, UL 94 V-0
Place of installation	indoor installation
Degree of protection	IP 20
Capacity	2 module(s), DIN 43880
Approvals	KEMA, VDE, UL, VdS
Weight	242 g
Customs tariff number	85363030
GTIN	4013364108417
PU	1 pc(s)

DEHNguard

DG M TN 275 (952 200)

- Prewired complete unit consisting of a base part and plug-in protection modules
- High discharge capacity due to heavy-duty zinc oxide varistors / spark gaps
- High reliability due to "Thermo Dynamic Control" SPD monitoring device



Figure without obligation

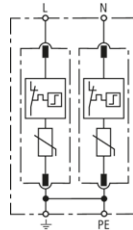

Basic circuit diagram DG M TN 275

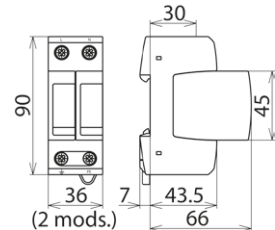

Dimension drawing DG M TN 275

Modular surge arrester for use in single-phase TN systems.

Type	DG M TN 275
Part No.	952 200
SPD according to EN 61643-11 / IEC 61643-11	type 2 / class II
Nominal a.c. voltage (U_N)	230 V (50 / 60 Hz)
Max. continuous operating a.c. voltage (U_C)	275 V (50 / 60 Hz)
Nominal discharge current (8/20 μ s) (I_n)	20 kA
Max. discharge current (8/20 μ s) (I_{max})	40 kA
Voltage protection level (U_P)	≤ 1.5 kV
Voltage protection level at 5 kA (U_{P5})	≤ 1 kV
Response time (t_A)	≤ 25 ns
Max. mains-side overcurrent protection	125 A gG
Short-circuit withstand capability for max. mains-side overcurrent protection (I_{SCCR})	50 kA _{rms}
Temporary overvoltage (TOV) (U_T) – Characteristic	335 V / 5 sec. – withstand
Temporary overvoltage (TOV) (U_T) – Characteristic	440 V / 120 min. – safe failure
Operating temperature range (T_U)	-40 °C ... +80 °C
Operating state / fault indication	green / red
Number of ports	1
Cross-sectional area (min.)	1.5 mm ² solid / flexible
Cross-sectional area (max.)	35 mm ² stranded / 25 mm ² flexible
For mounting on	35 mm DIN rails acc. to EN 60715
Enclosure material	thermoplastic, red, UL 94 V-0
Place of installation	indoor installation
Degree of protection	IP 20
Capacity	2 module(s), DIN 43880
Approvals	KEMA, VDE, UL, VdS
Weight	229 g
Customs tariff number	85363030
GTIN	4013364108394
PU	1 pc(s)

BLITZDUCTOR XT

BXT ML2 BD HFS 5 (920 271)

- LifeCheck SPD monitoring function
- Minimal signal interference
- For installation in conformity with the lightning protection zone concept at the boundaries from $0_A -2$ and higher



Figure without obligation

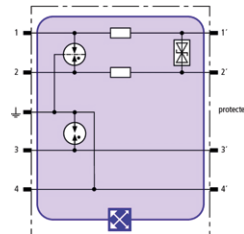

Basic circuit diagram BXT ML2 BD HFS

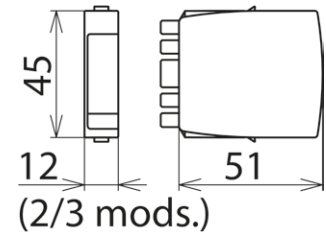

Dimension drawing BXT ML2 BD HFS

Space-saving combined lightning current and surge arrester module with LifeCheck feature for protecting one pair of unearthed high-frequency bus systems or video transmission systems, with direct or indirect shield earthing. If LifeCheck detects thermal or electrical overload, the arrester has to be replaced. This status is indicated contactlessly by the DEHNrecord LC / SCM / MCM reader.

Type	BXT ML2 BD HFS 5
Part No.	920 271
SPD monitoring system	LifeCheck
SPD class	TYPE 1 P1
Nominal voltage (U_N)	5 V
Max. continuous operating d.c. voltage (U_c)	6.0 V
Max. continuous operating a.c. voltage (U_c)	4.2 V
Nominal current at 45 °C (I_L)	1.0 A
D1 Total lightning impulse current (10/350 μ s) (I_{imp})	9 kA
D1 Lightning impulse current (10/350 μ s) per line (I_{imp})	2.5 kA
C2 Total nominal discharge current (8/20 μ s) (I_n)	20 kA
C2 Nominal discharge current (8/20 μ s) per line (I_n)	10 kA
Voltage protection level line-line for I_{imp} D1 (U_p)	≤ 25 V
Voltage protection level line-PG for I_{imp} D1 (U_p)	≤ 550 V
Voltage protection level line-line at 1 kV/ μ s C3 (U_p)	≤ 11 V
Voltage protection level line-PG at 1 kV/ μ s C3 (U_p)	≤ 550 V
Series resistance per line	1.0 ohm(s)
Cut-off frequency line-line (f_c)	100.0 MHz
Capacitance line-line (C)	≤ 25 pF
Capacitance line-PG (C)	≤ 25 pF
Operating temperature range (T_U)	-40 °C ... +80 °C
Degree of protection (plugged-in)	IP 20
Pluggable into	BXT BAS / BSP BAS 4 base part
Earthing via	BXT BAS / BSP BAS 4 base part
Enclosure material	polyamide PA 6.6
Colour	yellow
Test standards	IEC 61643-21 / EN 61643-21, UL 497B
SIL classification	up to SIL3 ^{*)}
ATEX approvals	DEKRA 11ATEX0089 X: II 3 G Ex nA IIC T4 Gc
IECEx approvals	DEK 11.0032X: Ex nA IIC T4 Gc
CSA & USA Hazloc approvals (1)	2516389: Class I Div. 2 GP A, B, C, D T4
CSA & USA Hazloc approvals (2)	2516389: Class I Zone 2, AEx nA IIC T4
Approvals	CSA, UL, GOST, VdS
Weight	22 g
Customs tariff number	85363010
GTIN	4013364117556
PU	1 pc(s)

^{*)} For more detailed information, please visit www.dehn-international.com.

BLITZDUCTOR SP

BSP M2 BD HF 5 (926 271)

- Minimal signal interference
- For installation in conformity with the lightning protection zone concept at the boundaries from 0_B-2 and higher



Figure without obligation

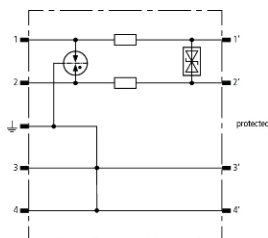

Basic circuit diagram BSP M2 BD HF 5

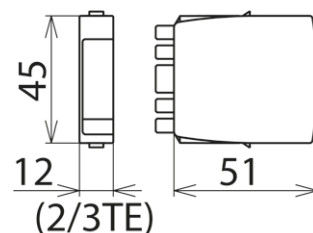

Dimension drawing BSP M2 BD HF 5

Space-saving surge arrester module for protecting one pair of high-frequency bus systems or video transmission systems with galvanic isolation.

Type	BSP M2 BD HF 5
Part No.	926 271
SPD class	TYPE 2 P1
Nominal voltage (U_N)	5 V
Max. continuous operating d.c. voltage (U_C)	6.0 V
Max. continuous operating a.c. voltage (U_C)	4.2 V
Nominal current at 45 °C (I_L)	1.0 A
C2 Total nominal discharge current (8/20 μ s) (I_n)	20 kA
C2 Nominal discharge current (8/20 μ s) per line (I_n)	10 kA
Voltage protection level line-line for I_n C2 (U_p)	≤ 35 V
Voltage protection level line-PG for I_n C2 (U_p)	≤ 600 V
Voltage protection level line-line at 1 kV/ μ s C3 (U_p)	≤ 11 V
Voltage protection level line-PG at 1 kV/ μ s C3 (U_p)	≤ 550 V
Series impedance per line	1.0 ohm(s)
Cut-off frequency line-line (f_c)	100 MHz
Capacitance line-line (C)	≤ 25 pF
Capacitance line-PG (C)	≤ 25 pF
Operating temperature range (T_U)	-40 °C ... +80 °C
Degree of protection (plugged-in)	IP 20
Pluggable into	BXT BAS / BSP BAS 4 base part
Earthing via	BXT BAS / BSP BAS 4 base part
Enclosure material	polyamide PA 6.6
Colour	yellow
Test standards	IEC 61643-21, UL 497B
SIL classification	up to SIL3 ^{*)}
Approvals	UL, CSA
Weight	21 g
Customs tariff number	85363010
GTIN	4013364127142
PU	1 pc(s)

^{*)} For more detailed information, please visit www.dehn-international.com.

BLITZDUCTOR

BXT BAS (920 300)

- Four-pole version for universal use with all types of BSP and BXT / BXTU protection modules
- No signal interruption if the protection module is removed
- Universal design without protection elements



Figure without obligation

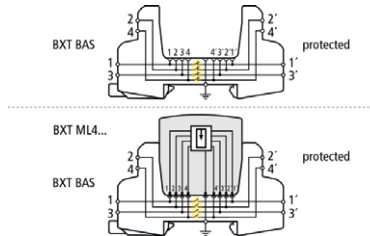

Basic circuit diagram with and without plugged-in module

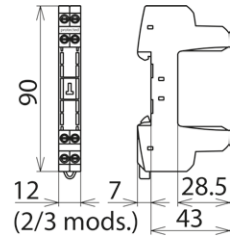

Dimension drawing BXT BAS

The BLITZDUCTOR XT base part is a very space-saving and universal four-pole feed-through terminal for the insertion of a protection module without signal interruption if the protection module is removed. The snap-in mechanism at the supporting foot of the base part allows the protection module to be safely earthed via the DIN rail. Since no components of the protective circuit are situated in the base part, only the protection modules must be maintained.

Type Part No.	BXT BAS 920 300
Operating temperature range (T _U)	-40 °C ... +80 °C
Degree of protection	IP 20
For mounting on	35 mm DIN rails acc. to EN 60715
Connection (input / output)	screw / screw
Signal disconnection	no
Cross-sectional area, solid	0.08-4 mm ²
Cross-sectional area, flexible	0.08-2.5 mm ²
Tightening torque (terminals)	0.4 Nm
Earthing via	35 mm DIN rails acc. to EN 60715
Enclosure material	polyamide PA 6.6
Colour	yellow
ATEX approvals	DEKRA 11ATEX0089 X: II 3 G Ex nA IIC T4 Gc ^{*)}
IECEx approvals	DEK 11.0032X: Ex nA IIC T4 Gc ^{*)}
Approvals	CSA, VdS, UL, GOST
Weight	34 g
Customs tariff number	85369010
GTIN	4013364109179
PU	1 pc(s)

^{*)} only in connection with an approved protection module

DEHNgate

DGA BNC VCID (909 711)

- Easily adaptable due to BNC sockets
- Available with direct or indirect shield earthing according to type
- For installation in conformity with the lightning protection zone concept at the boundaries from $0_B \dots 2$ and higher



Figure without obligation

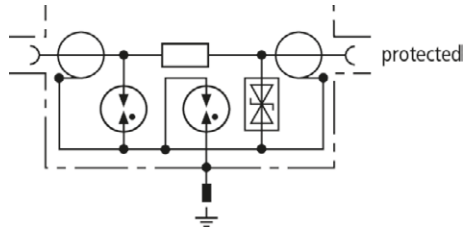

Basic circuit diagram DGA BNC VCID

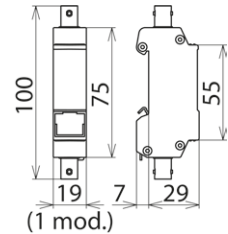

Dimension drawing DGA BNC VCID

Type	DGA BNC VCID
Part No.	909 711
SPD class	TYPE 2 Pt
Nominal voltage (U_N)	5 V
Max. continuous operating d.c. voltage (U_C)	6.4 V
Nominal current (I_N)	0.1 A
D1 Lightning impulse current (10/350 μ s) (I_{imp})	1 kA
C2 Nominal discharge current (8/20 μ s) shield-PG (I_n)	10 kA
C2 Nominal discharge current (8/20 μ s) line-shield (I_n)	5 kA
Voltage protection level line-shield for I_n C2 (U_p)	≤ 35 V
Voltage protection level shield-PG for I_n C2 (U_p)	≤ 650 V
Voltage protection level line-shield at 1 kV/ μ s C3 (U_p)	≤ 13 V
Voltage protection level shield-PG at 1 kV/ μ s C3 (U_p)	≤ 600 V
Frequency range	0-300 MHz
Insertion loss at 160 MHz	≤ 0.4 dB
Insertion loss at 300 MHz	≤ 3 dB
Return loss at 130 MHz	≥ 20 dB
Return loss at 300 MHz	≥ 10 dB
Characteristic impedance (Z)	50 ohms
Series resistance per line	4.7 ohms
Capacitance line-shield (C)	≤ 25 pF
Capacitance shield-PG (C)	≤ 20 pF
Operating temperature range (T_U)	-40 °C ... +80 °C
Degree of protection	IP 10
For mounting on	35 mm DIN rails according to EN 60715
Connection (input / output)	BNC socket / BNC socket
Earthing via	35 mm DIN rail according to EN 60715
Enclosure material	zinc die-casting
Colour	bare surface
Test standards	IEC 61643-21 / EN 61643-21
Approvals	CSA, UL, GOST
Weight	116 g
Customs tariff number	85366910
GTIN	4013364118980
PU	1 pc(s)

DEHNpatch

DPA M CAT6 RJ45S 48 (929 100)

- Ideally suited for retrofitting, protection of all lines
- CAT 6A in the channel according to ANSI/TIA/EIA-568
- Power over Ethernet (PoE+ according to IEEE 802.3at)
- For installation in conformity with the lightning protection zone concept at the boundaries from $0_B -2$ and higher



Figure without obligation

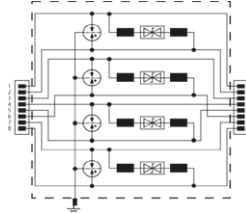

Basic circuit diagram DPA M CAT6 RJ45S 48

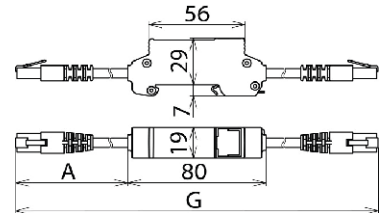

Dimension drawing DPA M CAT6 RJ45S 48

Universal arrester for Industrial Ethernet, Power over Ethernet (PoE+ according to IEEE 802.3at up to 57 V) and similar applications in structured cabling systems according to Cat. 6 and class E_A up to 500 MHz. Fully shielded type for DIN rail mounting.
Accessories: Earthing bracket with flat connector sleeve

Type	DPA M CAT6 RJ45S 48
Part No.	929 100
SPD class	TYPE 2 P₁
Nominal voltage (U _N)	48 V
Max. continuous operating d.c. voltage (U _c)	48 V
Max. continuous operating a.c. voltage (U _c)	34 V
Max. continuous operating d.c. voltage pair-pair (PoE) (U _c)	57 V
Nominal current (I _n)	1 A
D1 Lightning impulse current (10/350 μs) per line (I _{imp})	1 kA
C2 Nominal discharge current (8/20 μs) line-line (I _n)	150 A
C2 Nominal discharge current (8/20 μs) line-PG (I _n)	2.5 kA
C2 Total nominal discharge current (8/20 μs) line-PG (I _n)	10 kA
C2 Nominal discharge current (8/20 μs) pair-pair (PoE) (I _n)	150 A
Voltage protection level line-line for I _n C2 (U _p)	≤ 190 V
Voltage protection level line-PG for I _n C2 (U _p)	≤ 600 V
Voltage protection level line-line for I _n C2 (PoE) (U _p)	≤ 600 V
Voltage protection level line-line at 1 kV/μs C3 (U _p)	≤ 145 V
Voltage protection level line-PG at 1 kV/μs C3 (U _p)	≤ 500 V
Voltage protection level pair-pair at 1 kV/μs C3 (PoE) (U _p)	≤ 600 V
Insertion loss at 250 MHz	≤ 2 dB
Capacitance line-line (C)	≤ 165 pF
Capacitance line-PG (C)	≤ 255 pF
Operating temperature range (T _u)	-20 °C ... +60 °C
Degree of protection	IP 20
For mounting on	35 mm DIN rails acc. to EN 60715
Connection (input / output)	RJ45 connecting line / RJ45 connecting line
Pinning	1/2, 3/6, 4/5, 7/8
Connecting line	A = approx. 0.5 m, G = approx. 3 m ¹⁾
Connector	Stewart 39 series
Earthing via	35 mm DIN rail acc. to EN 60715
Enclosure material	zinc die-casting
Colour	bare surface
Test standards	IEC 61643-21 / EN 61643-21
Transmission class according to ISO/IEC 11801	Cat. 6
Transmission class according to EN 50173-1	Class E _A
Transmission class according to ANSI/TIA/EIA-568	cat. 6A in the channel
Approvals	GHMT, GOST
Accessories	fixing material
Weight	244 g
Customs tariff number	85363010
GTIN	4013364102170
PU	1 pc(s)

¹⁾ Special lengths on request

DEHNpatch

DPA M CLE RJ45B 48 (929 121)

- Ideally suited for retrofitting, protection of all lines
- Cat. 6 in the channel (class E)
- Power over Ethernet (PoE+ according to IEEE 802.3at)
- For installation in conformity with the lightning protection zone concept at the boundaries from $0_B -2$ and higher



Figure without obligation

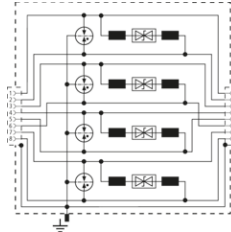

Basic circuit diagram DPA CLE RJ45B 48

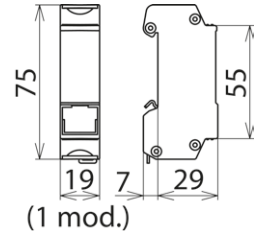

Dimension drawing DPA CLE RJ45B 48

Universal arrester for Industrial Ethernet, Power over Ethernet (PoE+ acc. to IEEE 802.3at up to 57 V) and similar applications in structured cabling systems according to class E up to 250 MHz. Protection of all pairs by means of powerful gas discharge tubes and one adapted filter matrix per pair. Fully shielded type with sockets for DIN rail mounting (up to 1 Gbit Ethernet).

Accessories: Earthing bracket with flat connector sleeve

Type	DPA M CLE RJ45B 48
Part No.	929 121
SPD class	TYPE 2 Pt
Nominal voltage (U_N)	48 V
Max. continuous operating d.c. voltage (U_c)	48 V
Max. continuous operating a.c. voltage (U_c)	34 V
Max. continuous operating d.c. voltage pair-pair (PoE) (U_c)	57 V
Nominal current (I_L)	1 A
D1 Lightning impulse current (10/350 μ s) per line (I_{imp})	0.5 kA
C2 Nominal discharge current (8/20 μ s) line-line (I_n)	150 A
C2 Nominal discharge current (8/20 μ s) line-PG (I_n)	2.5 kA
C2 Total nominal discharge current (8/20 μ s) line-PG (I_n)	10 kA
C2 Nominal discharge current (8/20 μ s) pair-pair (PoE) (I_n)	150 A
Voltage protection level line-line for I_n C2 (U_p)	≤ 180 V
Voltage protection level line-PG for I_n C2 (U_p)	≤ 500 V
Voltage protection level line-line for I_n C2 (PoE) (U_p)	≤ 600 V
Voltage protection level line-line at 1 kV/ μ s C3 (U_p)	≤ 180 V
Voltage protection level line-PG at 1 kV/ μ s C3 (U_p)	≤ 500 V
Voltage protection level pair-pair at 1 kV/ μ s C3 (PoE) (U_p)	≤ 600 V
Insertion loss at 250 MHz	≤ 3 dB
Capacitance line-line (C)	≤ 30 pF
Capacitance line-PG (C)	≤ 25 pF
Operating temperature range (T_U)	-40 °C ... +80 °C
Degree of protection	IP 10
For mounting on	35 mm DIN rails acc. to EN 60715
Connection (input / output)	RJ45 socket / RJ45 socket
Pinning	1/2, 3/6, 4/5, 7/8
Earthing via	35 mm DIN rail acc. to EN 60715
Enclosure material	zinc die-casting
Colour	bare surface
Test standards	IEC 61643-21 / EN 61643-21
Approvals	CSA, UL, GOST
Accessories	fixing material
Weight	123 g
Customs tariff number	85366910
GTIN	4013364118935
PU	1 pc(s)

UGKF BNC (929 010)

- Easily adaptable due to standard BNC connection
- Avoids leakage pickups
- For installation in conformity with the lightning protection zone concept at the boundaries from $0_B - 2$ and higher



Figure without obligation

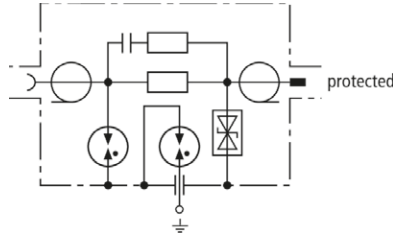

Basic circuit diagram UGKF BNC

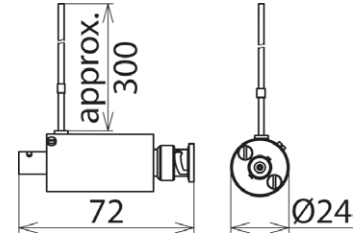

Dimension drawing UGKF BNC

Two-stage surge arrester for protecting video cameras and Arcnet with BNC connection with indirect shield earthing to avoid being influenced by leakage pickups.

Type	UGKF BNC
Part No.	929 010
SPD class	TYPE 2 Pt
Nominal voltage (U_N)	5 V
Max. continuous operating d.c. voltage (U_C)	8 V
Nominal current (I_N)	0.1 A
C2 Nominal discharge current (8/20 μ s) per line (I_n)	2.5 kA
C2 Nominal discharge current (8/20 μ s) shield-PG (I_n)	10 kA
Voltage protection level line-shield for I_n C2 (U_P)	≤ 25 V
Voltage protection level line-shield at 1 kV/ μ s C3 (U_P)	≤ 15 V
Voltage protection level shield-PG at 1 kV/ μ s C3 (U_P)	≤ 600 V
Insertion loss at 300 MHz (50 ohms)	≤ 3 dB
Return loss at 40 MHz (50 ohms)	≥ 20 dB
Insertion loss at 265 MHz (75 ohms)	≤ 3 dB
Return loss at 40 MHz (75 ohms)	≥ 20 dB
Characteristic impedance (Z)	50 ohms / 75 ohms
Series resistance per line	10 ohms
Capacitance line-shield (C)	≤ 50 pF
Operating temperature range (T_U)	-40 °C ... +80 °C
Connection (input / output)	BNC socket / BNC plug
Earthing via	outgoing earth conductor (0.75 mm ²)
Shield earthing	indirectly via an integrated spark gap
Test standards	IEC 61643-21 / EN 61643-21
Approvals	CSA, UL, GOST
Weight	68 g
Customs tariff number	85363010
GTIN	4013364039940
PU	1 pc(s)

www.dehn-international.com/partners



**Surge Protection
Lightning Protection
Safety Equipment
DEHN protects.**

DEHN + SÖHNE
GmbH + Co.KG.

Hans-Dehn-Str. 1
Postfach 1640
92306 Neumarkt
Germany

Tel. +49 9181 906-0
Fax +49 9181 906-1100
info@dehn.de
www.dehn-international.com



www.dehn-international.com/partners

Type designations of products mentioned in the white paper being at the same time registered trademarks are not especially marked. So if there is no marking of TM or © this does not mean that the type designation is a free trade name. Neither it can be seen whether patents or utility models and other intellectual and industrial property rights are available. We reserve the right to introduce changes in performance, configuration and technology, dimensions, weights and materials in the course of technical progress. The figures are shown without obligation. Misprints, errors and modifications excepted. Reproduction in any form whatsoever is forbidden without our authorisation.

actiVsense, BLITZDUCTOR, BLITZPLANER, DEHN, DEHN Logo, DEHN schützt, DEHNbloc, DEHNfix, DEHNgrip, DEHNguard, DEHNport, DEHNQUICK, DEHNrapid, DEHNshield, DEHNSnap, DEHNventil, HVI, LifeCheck, Red/Line are protected by German Trade Mark, by Community Trade Mark (EU) and/or in other countries.